



Drainage pumps with set-back Vortex type impeller for pumping charged waters and liquids with suspended solids; ideal for civil and household applications. The single-phase version includes a built-in capacitor, a thermal protector and it can be equipped with a float switch.



Construction features

Pump body stainless steel with openings 1" ½ and 2"

Shell, motor cover, base support stainless steel



Impeller stainless steel Vortex type

Mechanical seal double seal with oil barrier: silicon carbide on pump side, sealing ring on motor side

Motor shaft stainless steel AISI 430

Free passage Ø max 28 mm

Max submergence 5 m

Liquid temperature 0 - 40 °C

Cable H07 RN8F, 10 m

G float switch

Motor

3~ 400V - 50Hz

2 Poles induction motor 1~ 230V - 50Hz
(with thermal protection)

Insulation class F

Protection degree IPX8

TYPE	LOTS			
	TRUCK		CONTAINER	
	PALLET (cm)	N° pumps	PALLET (cm)	N° pumps
DX	80×120×145	48	80×120×190	76

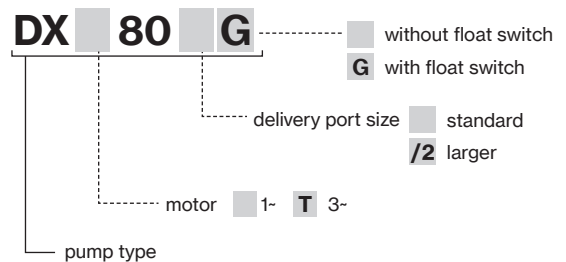

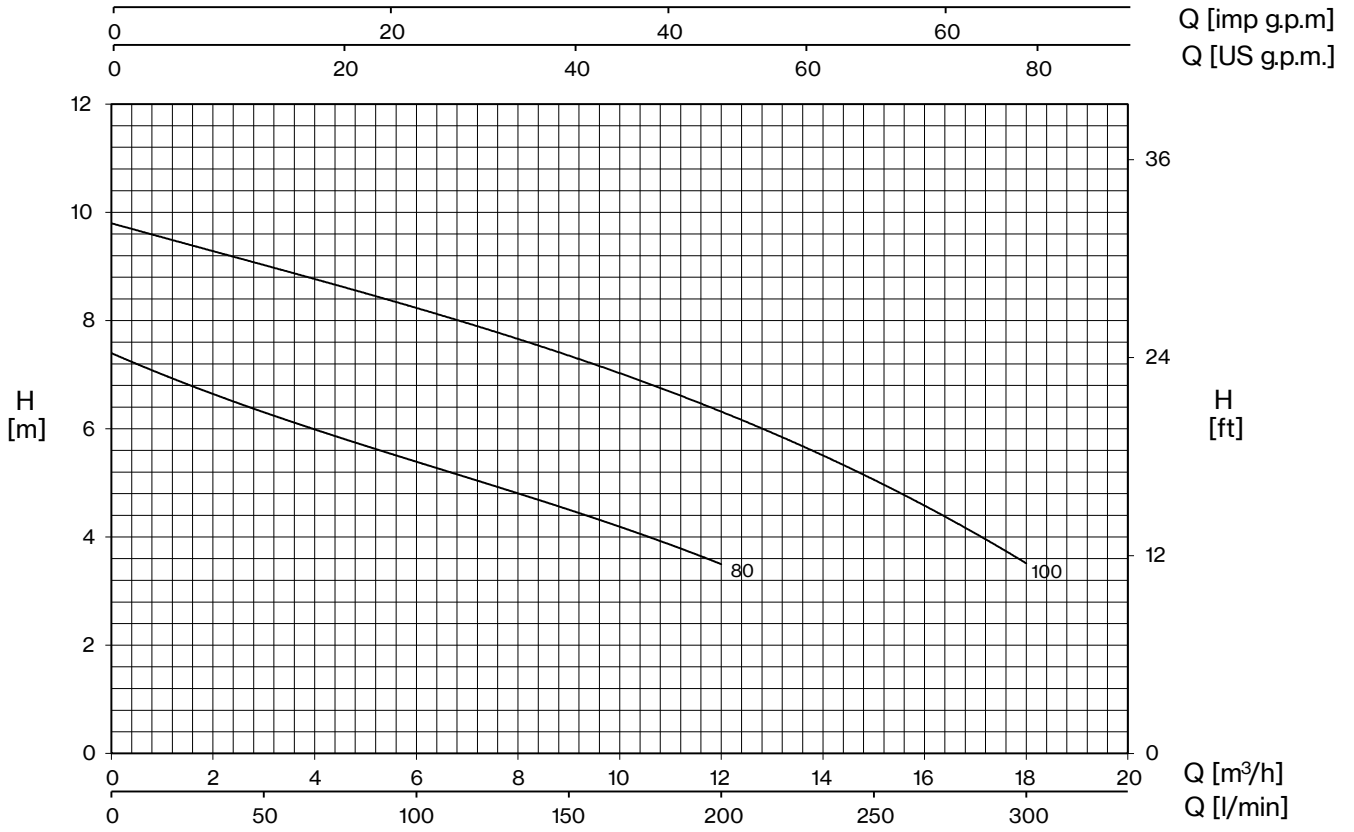

TYPE		W	AMPERE		Q (m³/h - l/min)							
1~	3~		1~ 1- 230V 50 Hz	3~ 3- 400V 50 Hz	0	3	6	9	12	15	18	
					0	50	100	150	200	250	300	
H (m)												
DX 80 (G)	DXT 80	1050	4,7	2,2	7,4	6,3	5,4	4,5	3,5			
DX 80/2 (G)	DXT 80/2	1050	4,7	2,2	7,4	6,3	5,4	4,5	3,5			
DX 100 (G)	DXT 100	1350	6,2	2,8	9,8	9,0	8,3	7,3	6,3	5,1	3,5	
DX 100/2 (G)	DXT 100/2	1350	6,2	2,8	9,8	9,0	8,3	7,3	6,3	5,1	3,5	

E: maximum emptying level
Mt: minimum liquid level for continuous duty

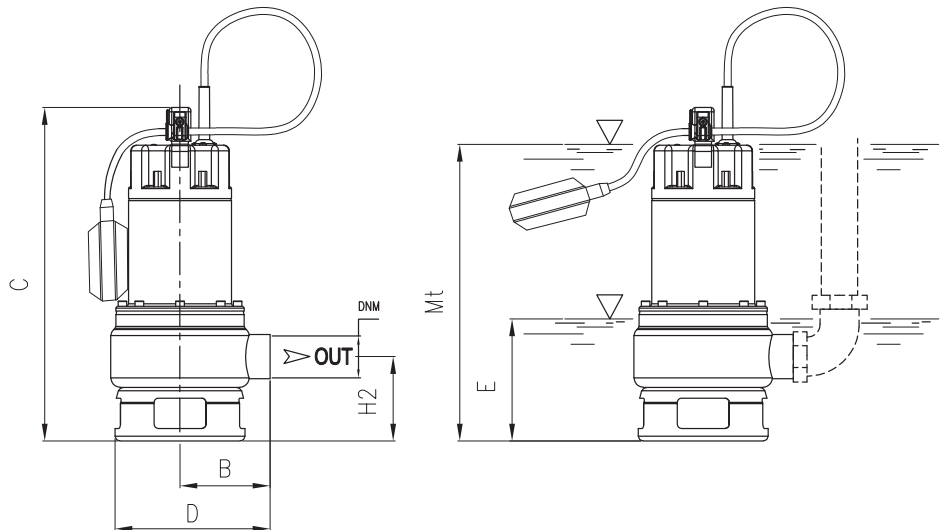

TYPE		DIMENSIONS (mm)										
1~	3~	B	C	D	E	H2	Mt	DNM	I	L	M	Kg
DX 80 (G)	DXT 80	104	400	183	125	112	280	1" ½ G	250	183	448	10,5
DX 80/2 (G)	DXT 80/2	114	400	183	125	112	280	2" G	250	183	448	10,5
DX 100 (G)	DXT 100	104	400	183	125	112	280	1" ½ G	250	183	448	12
DX 100/2 (G)	DXT 100/2	114	400	183	125	112	280	2" G	250	183	448	12

