

# ELECTRONIC FLOW CONTROL



**HIDROMATIC H2**

- Complete replacement of the traditional water system set consisting on pressure switch and pressure tank
- Control the starting of the electric pump after a pressure decrease (taps opening) and stopping when the fluid flow interrupt at the maximum pressure level of the electric pumps (taps closing)
- Protection against dry running
- Starting pressure adjustable during the installation
- Standard 1" M hydraulic connections
- Installation in any position - both vertical and horizontal according to the flow direction
- Easily replaceable electronic printed circuit board
- No need of maintenance

TECHNICAL DATA	
<b>Power supply</b>	110-230V ac ± 10% 50/60Hz
<b>Max rated current</b>	12 A
<b>Starting pressure range</b>	1 - 3,5 bar
<b>Max pressure</b>	10 bar
<b>Protection degree</b>	IP65
<b>Max fluid temperature</b>	55 °C
<b>Max ambient temperature</b>	55 °C



**HIDROTANK H2**

- Automatic start and stop operations of single-phases electric pumps up to 2 HP
- Replacement of the traditional water system set consisting on pressure switch and pressure tank
- Control the starting of the electric pump after a pressure decrease (taps opening) and stopping when the fluid flow interrupt at the maximum pressure level of the electric pumps (taps closing)
- Protection against dry running
- Starting pressure adjustable during the installation
- Standard 1" M hydraulic connections
- Installation in any position-both vertical and horizontal - according to the flow direction.
- Easily replaceable electronic printed circuit board
- No need of maintenance
- Thanks to the 0,4 lt. tank it protects from the frequent start-stop required by small request of water and from any losses into the system
- Protection of the electronic board thanks to the new watertight compartment
- Protection from water-hammer
- New design and new concept
- Built in 0,4 lt. tank
- Built in pressure gauge
- Watertight electronic part

TECHNICAL DATA	
<b>Power supply</b>	230Vac ± 15% 50/60Hz
<b>Max rated current</b>	12 A (2HP) - 1500 W
<b>Starting pressure range</b>	1 ÷ 3,5 bar (1,5 bar factory setting)
<b>Max pressure</b>	10 bar
<b>Protection degree</b>	IP65
<b>Fluid temperature</b>	5°C ÷ 35 °C
<b>Ambient temperature</b>	5°C ÷ 45°C
<b>Hydraulic connection</b>	1" M



# VARIABLE SPEED DRIVE



EPIC is a single-phase variable speed drive for horizontal and vertical three-phase pumps, designed to maintain the set pressure and protect a pumping system against dry running, over/under voltage and overcurrent.

It is possible to realize a booster set up to 2 pumps in parallel, using 2 EPIC connected together.

- Constant pressure control
- Easy initial configuration
- Installed directly on motor terminal box of horizontal or vertical pumps
- Soft start and soft stop
- Alternance for uniform pump wearing when connected to another EPIC
- Protection against dry running (adjustable power factor  $\cos\phi$ ), overload, overcurrent
- Automatic restart in case of stop for dry running
- Fuse for input protection of the device
- Led indicator for standby, run and alarm conditions
- Compatibility for residential environment thanks to an integrated electronic power factor corrector in compliance to EN61000-3-2
- 2 digital inputs (N.O. or N.C.) for motor run/stop
- 2 analog inputs: 4-20 mA and 0-10 VDC
- 1 digital output (N.O. or N.C.) for alarm signal

Input rated voltage	Output rated voltage	Output rated current	Max electric pump current	Weight
1 x 220 V	3 x 220 V	7,5 A	6,8 A	2,5 Kg

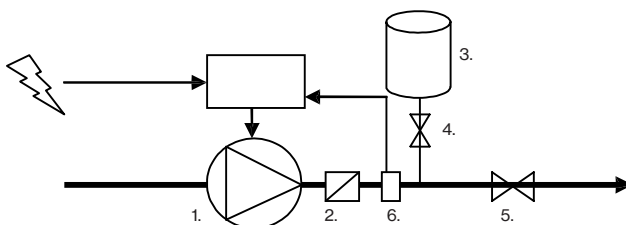

1. Pump
2. Non return valve
3. Pressure tank (*Volume suggested: 10% of the pump flow rate*)
4. Valve-Tap
5. Valve
6. Pressure sensor

VSD	TYPE	max nominal power P2	
		HP	kW
EPIC (1- V-in 3- V-out)	CAM, CAB, MB, CM, CS 2", CB	2	1,5
	INOX, CH	1,5	1,1
	MPX	1,2	0,88
	U 3, U 3S, U 3V, U 3L, U 3SV, U 3SL	2,5	1,85
	U 5, U 5S, U 5V, U 5L, U 5SV, U 5SL, U 9, U 9S	1,8	1,3
	U 7, U 7S	2,5	1,84

# VARIABLE SPEED DRIVE



**EPIC-A 204-209**  
**EPIC-A 304-309**

**EPIC-A 214-244**  
**EPIC-A 314-344**

EPIC-A (Advanced) is a three-phase variable speed drive for horizontal and vertical three-phase pumps designed to maintain the set pressure and protect pumping systems up to 8 pumps connected in parallel.

- Constant pressure control
- Easy initial configuration
- Simplified installation on motor terminal box of horizontal or vertical pumps
- Soft start and soft stop
- Alternance for uniform pump wearing when connected to others EPIC-A
- Built-in protections against overvoltage and undervoltage, overcurrent and no load, dry running, overtemperature
- Led indicator for standby, run and alarm conditions
- Compatibility for residential environment thanks to an integrated electronic power factor corrector in compliance to EN61000-3-2
- Integrated input filter for category C2 (EN61800-3), class A (EN55011)
- 4 digital inputs (N.O. or N.C.) for motor run/stop
- 4 analog inputs: two 4-20 mA and two 0-10 VDC
- 2 digital outputs (N.O. or N.C.) for alarm signal

EPIC-A	204	206	209	214	218	225	230	238	244
<b>Input rated voltage</b>	3 × 220 V ± 15%								
<b>Output rated voltage</b>	3 × 220 V								
<b>Output rated current</b>	4 A	6 A	9 A	14 A	18 A	25 A	30 A	38 A	44 A
<b>Max electric pump current</b>	3,6 A	5,4 A	8,1 A	12,6 A	16,2 A	22,5 A	27 A	34,2 A	39,6 A

EPIC-A	304	306	309	314	318	325	330	338	344
<b>Input rated voltage</b>	3 × 380 V ± 15%								
<b>Output rated voltage</b>	3 × 380 V								
<b>Output rated current</b>	4 A	6 A	9 A	14 A	18 A	25 A	30 A	38 A	44 A
<b>Max electric pump current</b>	3,6 A	5,4 A	8,1 A	12,6 A	16,2 A	22,5 A	27 A	34,2 A	39,6 A

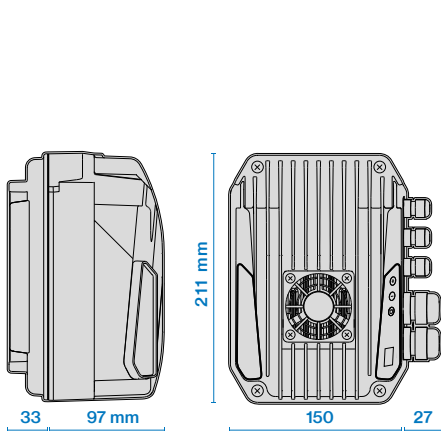

EPIC-A 204 - 206 - 209 - 304 - 306 - 309  
max weight 2,5 kg

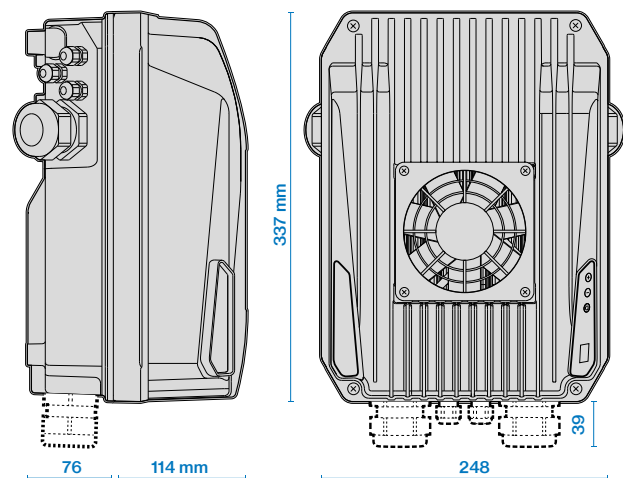

EPIC-A 214 - 218 - 225 - 230 - 238 - 244 -  
314 - 318 - 325 - 330 - 338 - 344  
max weight 10 kg



## VARIABLE SPEED DRIVE



IPFC is a variable speed drive for vertical pumps designed to control and protect pumping systems up to 8 pumps connected in parallel.

IPFC maintains the set pressure ensuring energy savings and extended lifespan of the system.

- Constant pressure control
- Energy and cost saving
- Protection against overload and dry running
- Greater reliability and longevity of pumping system
- Installed directly on the motor fan cover of vertical pumps
- Indication of input current and supply voltage
- Soft start and soft stop
- Recording running hours and loggings errors and alarms reported by the system
- Connect to other devices to get combined operation with cascade control and pump alteration
- OLED display
- Settable digital outputs, N.O. or N.C.
- Protection and analog/digital inputs

IPFC	306	309	311	314	318	325	330	338	348	365	375	385
<b>Input rated voltage (V)</b>	3 × 380 ± 15%											
<b>Output rated voltage (V)</b>	3 × 380											
<b>Output rated current (A)</b>	(3-) 6	(3-) 9	(3-) 11	(3-) 14	(3-) 18	(3-) 25	(3-) 30	(3-) 38	(3-) 48	(3-) 65	(3-) 75	(3-) 85
<b>Output rated power (kW)</b>	(3-) 2,2	(3-) 4	(3-) 4	(3-) 5,5	(3-) 7,5	(3-) 11	(3-) 15	(3-) 18,5	(3-) 22	(3-) 30	(3-) 37	(3-) 45
<b>Max electric pump current (A)</b>	(3-) 5,4	(3-) 8,1	(3-) 9,9	(3-) 12,6	(3-) 16,2	(3-) 22,5	(3-) 27	(3-) 34,2	(3-) 43,2	(3-) 58,5	(3-) 67,5	(3-) 76,5
<b>Input frequency (Hz)</b>	60											
<b>PWM frequency (kHz)</b>	2,5 - 4 - 6 - 8 - 10 - 12											
<b>Control panel</b>	backlight LCD with 2 x 16 characters and buzzer / Bluetooth® SMART 4,0											
<b>Input analogical signals (mA)</b>	no.4 4-20											
<b>Input digital signals</b>	no.2											
<b>Comunication</b>	RS485 / Bluetooth SMART 4,0											
<b>2 DOL auxiliary pump contacts</b>	clean, N.O., 220 V, I <sub>max</sub> , 6 A											
<b>Cooling</b>	auxiliar built-in cooling fan / mot fan											
<b>Protection degree</b>	IP55 (IP54 for IPFC 338 < > IPFC 385)											
<b>Assembly</b>	on motor fan cover with kit / hanged on wall with kit						on motor feet / hanged on wall with kit					
<b>Max ambient temperature (C)</b>	40° C											
<b>Max ambient altitude</b>	1.000 m slm / de-rate 2% each 100 m											
<b>Input / Output feeding cable</b>	2 × PG 13,5 + 3 × PG 9											
<b>Dimension (mm)</b>	205 × 205 × h180			260 × 260 × h180				410 × 260 × h680				

# IPFC V. 220 VSD

IPFC	109	114	206	209	214	218	225	230	238	248	265	275	285
<b>Input rated voltage (V)</b>	1 × 220 ± 15%		3 × 220 ± 15%										
<b>Output rated voltage (V)</b>	1 × 220 3 × 220		3 × 220										
<b>Output rated current (A)</b>	(1-) 9 (3-) 7	(1-) 9 (3-) 11	(3-) 6	(3-) 9	(3-) 14	(3-) 18	(3-) 25	(3-) 30	(3-) 38	(3-) 48	(3-) 65	(3-) 75	(3-) 85
<b>Output rated power (kW)</b>	(1-) 1,1 (3-) 1,5	(1-) 1,1 (3-) 3	(3-) 1,1	(3-) 2,2	3 kW 3-	(3-) 4	(3-) 5,5	(3-) 7,5	(3-) 9,3	(3-) 11	(3-) 15	(3-) 18,5	(3-) 22
<b>Max motor current (A)</b>	(1-) 7,2 (3-) 6,3	(1-) 7,2 (3-) 9,9	(3-) 5,4	(3-) 8,1	(3-) 12,6	(3-) 16,2	(3-) 22,5	(3-) 27	(3-) 34,2	(3-) 43,2	(3-) 58,5	(3-) 67,5	(3-) 76,5
<b>Input frequency (Hz)</b>	60												
<b>PWM frequency (kHz)</b>	2,5 - 4 - 6 - 8 - 10 - 12												
<b>Control panel</b>	backlight LCD with 2 x 16 characters and buzzer / Bluetooth® SMART 4,0												
<b>Input analogical signals (mA)</b>	no.4 4-20												
<b>Input digital signals</b>	no.2												
<b>Communication</b>	RS485 / Bluetooth SMART 4,0												
<b>2 DOL auxiliary pump contacts</b>	clean, N.O., 220 V, I <sub>max</sub> , 6 A												
<b>Cooling</b>	Auxiliar built-in cooling fan / mot fan												
<b>Protection degree</b>	IP55 (IP54 for IPFC 338 < > IPFC 385)												
<b>Assembly</b>	on motor fan cover with kit / hanged on wall with kit						on motor feet / hanged on wall with kit						
<b>Max ambient temperature (C)</b>	40°												
<b>Max ambient altitude</b>	1000 m slm / de-rate 2% each 100 m												
<b>Input / Output feeding cable</b>	2 × PG 13,5 + 3 × PG 9												
<b>Dimension (mm)</b>	205 × 205 × h180				260 × 260 × h180				410 × 260 × h680				



**SPD pressure transducer**

TYPE	Output signal	Input voltage	Working pressure	Maximum pressure
<b>SPD</b>	4... 20 mA	9... 28 V	0 - 16 bar 0 - 25 bar	32 bar



# PROTECTION/CONTROL PANEL

## Legend

SERIES	ELECTRICITY SUPPLY		N. PUMPS			PUMP TYPE			POWER P2 Kw	SPEED		MOTOR STARTER			FEATURE			
	1~	3~	1	2	3	Borehole	Submersible	Surface		Fixed	Variable	DOL	Y/Δ	Soft start	Impedance start	Switch with overload protection	Electromechanical control panel	Electronic control panel
PML	■	-	■	-	-	■	-	■	0,37 ÷ 2,2	■	-	■	-	-	-	■	-	-
PMC	■	-	■	-	-	■	-	■	1,1 ÷ 1,5	■	-	■	-	-	-	■	-	-
PMLD	■	-	■	-	-	-	-	-	1,1 ÷ 1,5	■	-	■	-	-	-	■	-	-
PT	-	■	■	-	-	■	-	■	0,37 ÷ 15	■	-	■	-	-	-	■	-	-
EQSM	■	-	■	-	-	■	■	■	0,37 ÷ 2,2	■	-	■	-	-	-	-	-	■
EQSMT	-	■	■	-	-	■	■	■	0,55 ÷ 15	■	-	■	-	-	-	-	-	■
QST	-	■	■	-	-	■	■	■	4,5 ÷ 220	■	-	-	■	-	-	-	-	■
QSS	-	■	■	-	-	■	-	■	7,5 ÷ 220	■	-	-	■	-	-	-	-	■
QRS	-	■	■	-	-	■	-	■	4,5 ÷ 220	■	-	-	-	■	-	-	-	■
EQ2SM	■	-	-	■	-	■	■	■	0,37 ÷ 15	■	-	■	-	-	-	-	-	■
EQ2SMT	-	■	-	■	-	■	■	■	0,55 ÷ 15	■	-	■	-	-	-	-	-	■
Q2ST	-	■	-	■	-	■	■	■	4,5 ÷ 220	■	-	-	■	-	-	-	-	■
EQ3SM	■	-	-	-	■	■	■	■	0,37 ÷ 2,2	■	-	■	-	-	-	-	-	■
EQ3SMT	-	■	-	-	■	■	■	■	0,55 ÷ 15	■	-	■	-	-	-	-	-	■

## Overload protection unit for 1 single-phase pump with run capacitor



- Power supply 1x230V-50/60Hz
- Electrical switch
- Run capacitor
- Externally resettable thermal relay
- Illuminated 0-1 main switch
- IP55 rated thermoplastic enclosure
- Outputs with cable gland

TYPE	A	RUN CAPACITOR (μF)	POWER	
			HP	kW
PML 5/16-4	4	16	0,5	0,37
PML 5/20-4	4	20	0,5	0,37
PML 7/20-6	6	20	0,75	0,55
PML 7/25-6	6	25	0,75	0,55
PML 10/30-7	7	30	1	0,75
PML 10/35-7	7	35	1	0,75
PML 15/40-10	10	40	1,5	1,1
PML 20/50-13	13	50	2	1,5
PML 20/60-13	13	60	2	1,5
PML 30/75-18	18	75	3	2,2
PML 30/80-18	18	80	3	2,2
PMC 15/35-15	15	35	1,5	1,1
PMC 20/50-18	18	50	2	1,5

## PROTECTION/CONTROL PANEL

### Overload protection unit for 1 single-phase pump with run capacitor + start capacitor with disjunctor



PMLD

- Power supply 1x230V-50/60Hz
- ON/OFF switch
- Electrical switch
- Run + start capacitor with disjunctor
- Externally resettable thermal relay
- Green illuminated main switch
- IP55 rated thermoplastic enclosure
- Outputs with cable gland

TYPE	A	RUN CAPACITOR (μF)	START CAPACITOR (μF)	POWER	
				HP	kW
PMLD 15-35-13	13	35	80	1,5	1,1
PMLD 20/50-15	15	50	80	2	1,5

### Overload protection unit for 1 three-phase pump



PT

- Power supply 3x400V-50/60Hz
- ON/OFF switch
- Protective device with thermal relay for motor overload or phase failure
- Thermoplastic enclosure
- IP55 protection level

TYPE	A	POWER	
		HP	kW
PT 5/0,9-1,3	0,9-1,3	0,5	0,37
PT 7/1,3-2,1	1,3-2,1	0,75	0,55
PT 10/1,9-3	1,9-3	1	0,75
PT 15-20/2,9-4,5	2,9-4,5	1,5-2	1,1-1,5
PT 20-30-40/4,3-6,8	4,3-6,8	2-3-4	2,2-3
PT 40-50/5,7-9,1	5,7-9,1	4-5,5	3-4
PT 55-75/8,6-13,5	8,6-13,5	5,5-7,5	4-5,5
PT 100/12,5-16,5	12,5-16,5	10	7,5
PT 125-150-16-21	16-21	12,5-15	9,2-11
PT 200/22-29	22-29	20	15

## Electronic control panel for 1-2-3 pumps with direct start-up



- Single-phase version 100-240Vac 50/60Hz
- Three-phase version 310-450Vac 50/60Hz
- LCD display for voltage, current, power factor, hours of operation, number of starts, motor status, alarms, analogue signal and thresholds
- AUTOMATIC - 0 - MANUAL operation buttons
- Voltage and current minimum and maximum electronic control, failure or incorrect phase sequence control on power supply input
- Programmable anti-seize autotest
- Dry running protection through level probes/ floats/ pressure switches and minimum current
- Up to 6 control inputs: floats/pressure switches
- Input for 4-20 mA or 0-10V analogue signal
- Analogue signal cm - m - bar
- Emergency start and stop inputs with analogue signal
- Clickson thermal pad inputs with automatic reset
- Inversion of inputs (from normally open to normally closed)
- Activation delay from mains return
- Manual button operation (fixed or pulse)
- Programmable alarms for voltage, levels, motor overload, minimum motor current, clicson, output contacts, starts/hour
- Automatic reset for minimum current alarm with 4 programmable times
- Auxiliary and motor protection fuses, isolator protection, duty standby protection
- ABS box IP55. Metallic box IP55 for EQ3SMT
- Duty-standby and motor changeover in the case of a fault for two-pump and three-pump control panels
- Predisposition for capacitors for single-phase versions (capacitors are available separately)

TYPE	VERSION	PUMPS N.	A	POWER		WEIGHT (Kg)
				HP	kW	
EQSM	1-	1	0-18	0,5-3	0,37-2,2	1,5
EQSMT 10	3-	1	0-18	0,75-10	0,55-7,5	2,3
EQSMT 15	3-	1	16-25	10-15	7,5-11	2,5
EQSMT 20	3-	1	16-32	15-20	11-15	3
EQ2SM	1-	2	0-18	0,5-3	0,37-2,2	1,5
EQ2SMT 10	3-	2	0-18	0,75-10	0,55-7,5	2,5
EQ2SMT 15	3-	2	16-25	10-15	7,5-11	3
EQ2SMT 20	3-	2	16-32	15-20	11-15	3,5
EQ3SM	1-	3	0-18	0,5-3	0,37-2,2	5
EQ3SMT 10	3-	3	0-18	0,75-10	0,55-7,5	15
EQ3SMT 15	3-	3	16-25	10-15	7,5-11	15
EQ3SMT 20	3-	3	16-32	15-20	11-15	15



RUN CAPACITOR	POWER
	HP
20µF	0,5
25µF	0,75
35µF	1-1,5
40µF	1,5
50µF	2
80µF	3

RUN CAPACITOR + START CAPACITOR WITH DISJUNCTOR	POWER
	HP
35µF + 80µF	1,5
50µF + 80µF	2



## PROTECTION/CONTROL PANEL

### Star/delta control panel for 1 three-phase pump



- Power supply 3x400V-50/60Hz
- 24V transformer for auxiliary circuit
- Low voltage inputs and circuits
- Blue mains supply LED
- Green motor running LED
- Red motor overload alarm LED
- Star/delta line contactors in AC3
- Auxiliary and motor protective devices with fuses
- Main door interlock switch disconnecter
- ABS box up to 11kW, metal box from 15kW

TYPE	A	POWER	
		HP	kW
QST 5	13	5,5	4
QST 7	15	7,5	5,5
QST 10	17	10	7,5
QST 15	24	15	11
QST 20	31	20	15
QST 25	38	25	18,5
QST 30	50	30	22
QST 40	60	40	30
QST 50	75	50	37
QST 60	100	60	45
QST 75	124	75	55
QST 100	135	100	75
QST 125	155	125	92
QST 150	200	150	110
QST 180	241	180	132
QST 220	300	220	162
QST 300	410	300	220

### Star/delta control panel for 2 three-phase pumps

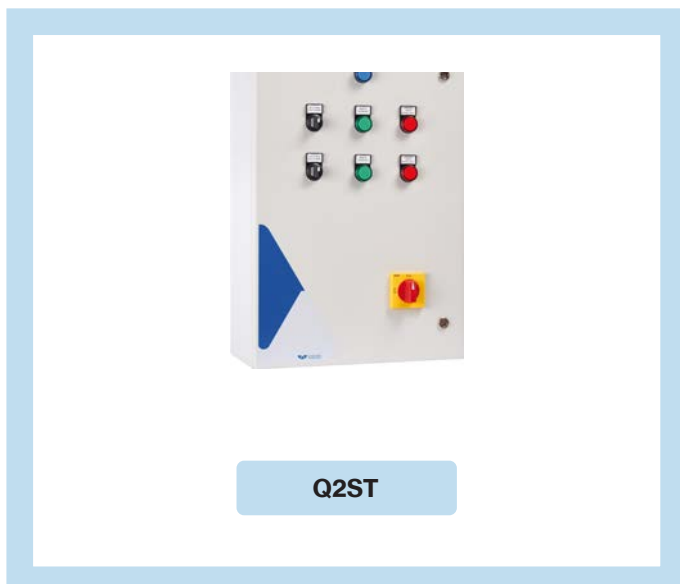

- Power supply 3x400V-50/60Hz
- 24V transformer for auxiliary circuit
- Low voltage inputs and circuits
- Blue mains supply LED
- Green motor running LED
- Red motor overload alarm LED
- Star/delta line contactors in AC3
- Auxiliary and motor protective devices with fuses
- Main door interlock switch disconnecter
- Metal box (whole range)

TYPE	A	POWER	
		HP	kW
Q2ST 3	8,5	3	2,2
Q2ST 5	13	5,5	4
Q2ST 7	15	7,5	5,5
Q2ST 10	17	10	7,5
Q2ST 15	24	15	11
Q2ST 20	31	20	15
Q2ST 25	38	25	18,5
Q2ST 30	50	30	22
Q2ST 40	60	40	30
Q2ST 50	75	50	37
Q2ST 60	100	60	45
Q2ST 75	124	75	55
Q2ST 100	135	100	75
Q2ST 125	155	125	92
Q2ST 150	200	150	110
Q2ST 180	241	180	132
Q2ST 220	300	220	162
Q2ST 300	410	300	220

## PROTECTION/CONTROL PANEL

### Soft start control panel for 1 three-phase pump



- Power supply 3x400V-50/60Hz
- Blue mains supply LED
- Green motor running LED
- Red motor overload alarm LED
- NA input for start control
- Auxiliary motor protective devices with fuse
- Main door interlock switch disconnecter
- Forced ventilation kit
- IP54 rated metal box
- Ambient temperature  $-5 \div +40^{\circ}\text{C}$

TYPE	A	POWER	
		HP	kW
QSS 10	18	10	7,5
QSS 15	25	15	11
QSS 20	30	20	15
QSS 25	37	25	18,5
QSS 30	45	30	22
QSS 40	60	40	30
QSS 50	72	50	37
QSS 60	85	60	45
QSS 75	105	75	55
QSS 80	125	80	59
QSS 100	142	100	75
QSS 125	170	125	92
QSS 150	210	150	110
QSS 180	250	180	132
QSS 220	300	220	162
QSS 300	370	300	220

### Control panel with impedance start for 1 three-phase pump



- Power supply 3x400V-50/60Hz
- Blue mains supply LED
- Green motor running LED
- Red motor overload alarm LED
- NA input for start control
- Stator reactance with 4 starts/hour, 2 of which are consecutive
- Adjustable reactance timer
- Line and impedance starter contactors in AC3
- Main door interlock switch disconnecter
- Ambient temperature  $-5 \div +40^{\circ}\text{C}$

TYPE	A	POWER	
		HP	kW
QRS 5	13	5,5	4
QRS 7	16	7,5	5,5
QRS 10	20	10	7,5
QRS 15	29	15	11
QRS 20	35	20	15
QRS 25	52	25	18,5
QRS 30	63	30	22
QRS 40	80	40	30
QRS 50	90	50	37
QRS 60	110	60	45
QRS 75	135	75	55
QRS 90	150	90	66
QRS 100	175	100	75
QRS 125	200	125	92
QRS 150	235	150	110
QRS 180	310	180	132
QRS 220	360	220	162
QRS 300	410	300	220

# TANKS



## UTILIZATION

Interchangeable membrane expansion tanks; the pre-charge pressure in the tank guarantees a water reserve but also reduces the number of startups of the connected pump; the membranes are certified for use with foodstuffs; they may be in EPDM or butyl depending on the model.

## CONSTRUCTION CHARACTERISTICS

Flanges in galvanised steel or AISI 304 stainless steel. Tanks in carbon steel coated with powder paint or in AISI 304 stainless steel.

Pre-charge valve with protective cover.

TYPE	DESCRIPTION
AS 24	24 lt. Spherical tank
ACV 24	24 lt. Horizontal tank
ACZ 24	24 lt. Horizontal tank
ACA 24 SS	24 lt. Stainless steel tank
AC 50	50 lt. Horizontal tank
AC 60	60 lt. Horizontal tank
AC 80	80 lt. Horizontal tank
AC 100	100 lt. Horizontal tank
AC 200	200 lt. Horizontal tank
AC 300	300 lt. Horizontal tank
AV 50	50 lt. Vertical tank
AV 60	60 lt. Vertical tank
AV 80	80 lt. Vertical tank
AV 100	100 lt. Vertical tank
AV 200	200 lt. Vertical tank
AV 300	300 lt. Vertical tank
AV 500	500 lt. Vertical tank
AV 750	750 lt. Vertical tank
AV 1000	1000 lt. Vertical tank

# MEMBRANES



TYPE	DESCRIPTION
MZ 24	EPDM membrane for ACZ 24 lt.
M 24	membrane for AS 24 - ACV 24
M 50	membrane for AC 50 - AV 50
M 100	membrane for AC 100 - AV 100
M 200	membrane for AC 200 - AV 200
M 300	membrane for AC 300 - AV 300
M 500	membrane for AV 500
M 750 - 2000	membrane for AV 750 - AV 2000



# PRESSURE SWITCHES



TYPE	DESCRIPTION	RANGE AT RISING PRESSURE (bar)
PP5	1- / 3-	1-5
PP12	1- / 3-	3-12

# PRESSURE GAUGES



TYPE	PHASE
PR 6	0-6 bar rear connection
PR 6 R	0-6 bar radial connection
PR 12	0-12 bar rear connection
PR 10 G	0-10 bar glycerine
PR 12 G	0-12 bar glycerine

# FLEXIBLE HOSES



TYPE	DESCRIPTION
FL 530	Flexible hose with bend 1"x530x1"
FL 600	Flexible hose with bend 1"x600x1"
FL 700	Flexible hose with bend 1"x700x1"
FL 850	Flexible hose with bend 1"x850x1"

# CONNECTORS



TYPE	DESCRIPTION
R3	3 way 1" brass connector
R5	5 way 1" brass connector



TYPE	DESCRIPTION
R5X 1"	5 way 1" Aisi 304 connector with built-in no return valve
R5X 1" 1/4	5 way 1" 1/4 Aisi 304 connector with built-in no return valve
R5X 1" 1/2	5 way 1" 1/2 Aisi 304 connector with built-in no return valve

# VALVES



TYPE	DESCRIPTION
VF 1"	foot valve 1"
VF 1" 1/4	foot valve 1" 1/4
VF 1" 1/2	foot valve 1" 1/2
VF 2"	foot valve 1" 1/2
VR1"	check valve 1"
VR 1" 1/4	check valve 1" 1/4
VR 1" 1/2	check valve 1" 1/2
VR 2"	check valve 1"

# FLOAT SWITCHES



TYPE	DESCRIPTION
GK 2	Key 2 mt. cable length
GK 3	Key 3 mt. cable length
GK 5	Key 5 mt. cable length
GK 10	Key 10 mt. cable length



# CABLES JOINTS

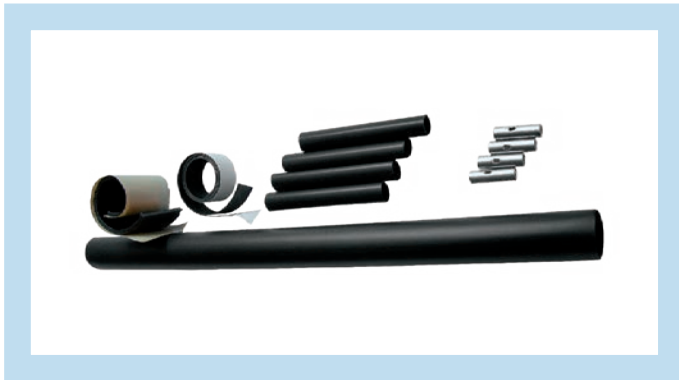

## Kit GC series

Junction cable kit with heat - shrinkable tubing.

For a professionally made junction it is recommended to use the "Kit GC", it has excellent requirements in terms of electric, mechanical and water resistance. This kit is composed of: crimp wire connectors in tinplated copper, thin wall heat-shrinkable tubing to cover the conductor of the cable, a strip of Scotch 2547, one of Scotchfil and medium wall heat-shrinkable tubing to cover the junction. It is recommended to seal the two end points of the sheath with a PVC textured insulating tape.

TYPE	Cables section mm <sup>2</sup>	Cable number
Kit GC 4/2,5	1/2,5	4
Kit GC 4/6	4/6	4
Kit GC 4/10	10	4
Kit GC 4/16	16	4
Kit GC 4/25	25	4
Kit GC 4/35	35	4
Kit GC 4/50	50	4
Kit GC 1/50	50	1
Kit GC 1/70	70	1
Kit GC 1/95	95	1
Kit GC 1/120	120	1
Kit GC 1/150	150	1

# LEVEL PROBES



## Kit K3SL series

Level Probes Kit consist of 3 electrodes model K3SL.

Single pole probe used for level control in wells or storage tanks.

It made of an AISI 303 stainless steel electrode, a plastic (PPOX) holder and a cable gland.

A seal ring and the tightening of the cable gland PG7 prevent water from entering the cable terminal connector and causing its oxidation.

Cable connection: screw.

The external cable diameter must be 2.5 to 6mm/Ø0.1 to 0.24" to warrant perfect sealing.

Maximum connection cable section: 2.5mm<sup>2</sup>.

Maximum operating temperature: +60°C.

